

The logo for autoCLOSER features the brand name in a bold, white, sans-serif font. The text is contained within a dark blue rounded rectangular box. This box is centered within a larger, irregular yellow shape that resembles a brushstroke or a splash, creating a dynamic and modern look.

**autoCLOSER**

Patent Pending

# INSTALLATION MANUAL AND USER'S GUIDE

Revision 5.8

Autocloser is designed and manufactured by



Made in  
the  
U.S.A.



NOTE: This equipment has been tested and found to comply with the limits for a Class B digital device, pursuant to part 15 of the FCC Rules. These limits are designed to provide reasonable protection against harmful interference in a residential installation. This equipment generates, uses and can radiate radio frequency energy and, if not installed and used in accordance with the instructions, may cause harmful interference to radio communications. However, there is no guarantee that interference will not occur in a particular installation. If this equipment does cause harmful interference to radio or television reception, which can be determined by turning the equipment off and on, the user is encouraged to try to correct the interference by one or more of the following measures:

- Reorient or relocate the receiving antenna.
- Increase the separation between the equipment and receiver.
- Connect the equipment into an outlet on a circuit different from that to which the receiver is connected.
- Consult the dealer or an experienced radio/TV technician for help.

CAUTION: Any modifications made to the Autocloser without express approval by Xceltronix, Inc. could void the user's authority to operate said equipment.

## *INTRODUCTION*

Congratulations on your purchase of an Autocloser automatic garage door closer. We are certain that this little black box will give you peace of mind knowing that your garage or shop door will close if you inadvertently leave it open. The Autocloser works with your existing garage door opener and incorporates the latest micro-controller technology, infrared light sensor, the optional I-Opener system, and advanced software algorithms to deliver a safe and reliable product.

The Autocloser functions by continuously monitoring the garage door position. When the device senses that the garage door is open, the device starts a software timer. When the timer completes its count, the Autocloser warns of the impending garage door closure then shuts the garage door. The operation of the garage door is achieved by connecting the device to the garage door opener wall button terminals. This enables the device to simulate the depression of the garage door opener wall button. The closing sequence can be cancelled by pressing the disable button (before the audible warning is given), or by pressing the disable button twice if the audible warning is sounding.

An optional subsystem, the I-Opener system, allows the Autocloser to open and close a garage door from a remote, secure terminal utilizing an electronic key. Each electronic key has a unique code that is permanently stored in the key. Each key provides one of 281,474,976,710,656 possible access combinations. That's 281 trillion possible numbers. If a thief wanted to circumvent the system by inputting every possible number, it would take 8,925,513 years because the I-Opener system reads only one key code per second. The I-Opener system is highly secure, easy to install and easy to operate.

### *PRE-INSTALLATION CHECK LIST*

- 1. Verify that your garage door opener complies with the latest government safety requirements.** The Consumer Products Safety Commission (<http://www.cpsc.gov>) has information on the latest garage door opener requirements mandated by Congress. Garage door openers installed after 1991 are required to have a properly working reversing mechanism. If this feature does not work on your system, your door could close on an object such as a child or car and cause severe injury or damage. Garage door openers installed after 1993 are required to have a photo eye mechanism. Unlike the reversing mechanism attached to the door, nothing has to physically touch the door before it reverses. Once the invisible beam from the photo eye is broken, the door reverses automatically. If your garage door does not have these government required safety features, replace or update your garage door opener with a compliant model before installing the Autocloser. The Autocloser has both an audible beeper and visible door movement alarm to indicate that the door is about to close. While

this is intended to increase the safety of the system, these features are not intended to nor do they replace the auto reversing safety features that are required on all garage door openers.

2. **Xceltronix, Inc. urges you to re-read your garage door opener installation and maintenance manual.** Perform routine maintenance and a safety inspection based on the recommendations of the garage door opener manufacturer. Test the auto-reversing and photo eye safety features.
3. **You need a 110 Volt power outlet available.** The outlet should be no more than four feet from the garage door opener power head.

**!!!WARNING!!!**

**DO NOT USE AN EXTENSION CORD! Extension cords can cause dangerous overheating conditions and are a fire hazard!**

4. **Instruct all family members, especially children, about the potential dangers of a garage door opener.** A garage door is the largest moving object in your house. All family members should be instructed to use caution around it. Never stand or play under the door, and never race underneath the door as it closes. Keep all body parts away from the garage door opener track and drive mechanisms.

#### TOOLS RECOMMENDED

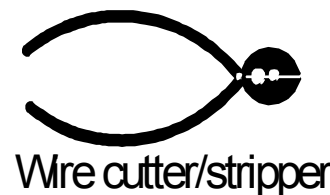
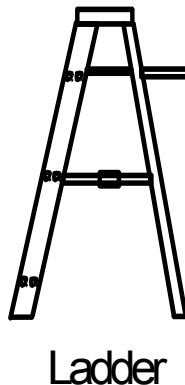
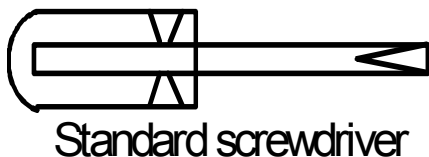
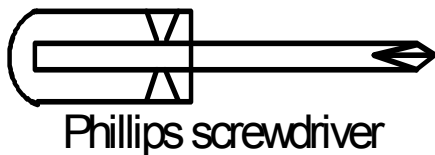
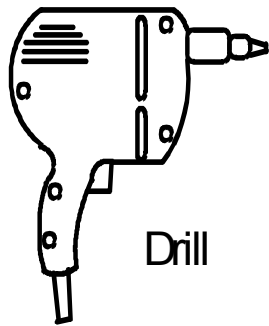

## **PARTS LIST**

<u>Item</u>	<u>Description</u>
1)	1 terminal wire 2ft.
2)	1 Disable wire 25 ft.
3)	1 Disable button
4)	Velcro® fasteners, 2 each- hook and loop strips
5)	1 Reflector assembly
6)	1 Nut
7)	1 Bolt
8)	1 Lock washer
9)	2 Disable button wood screws
10)	1 Power adaptor
11)	1 I-Opener terminal assembly (optional)
12)	2 I-Opener terminal plate wood screws (optional)
13)	1 I-Opener electronic key (optional)
14)	1 Autocloser control unit
15)	Conspicuity tape

*Note: Items (1) and (2) may be supplied as a single spool of wire. Cut the required length of wire for item (1) from the spool of wire.*

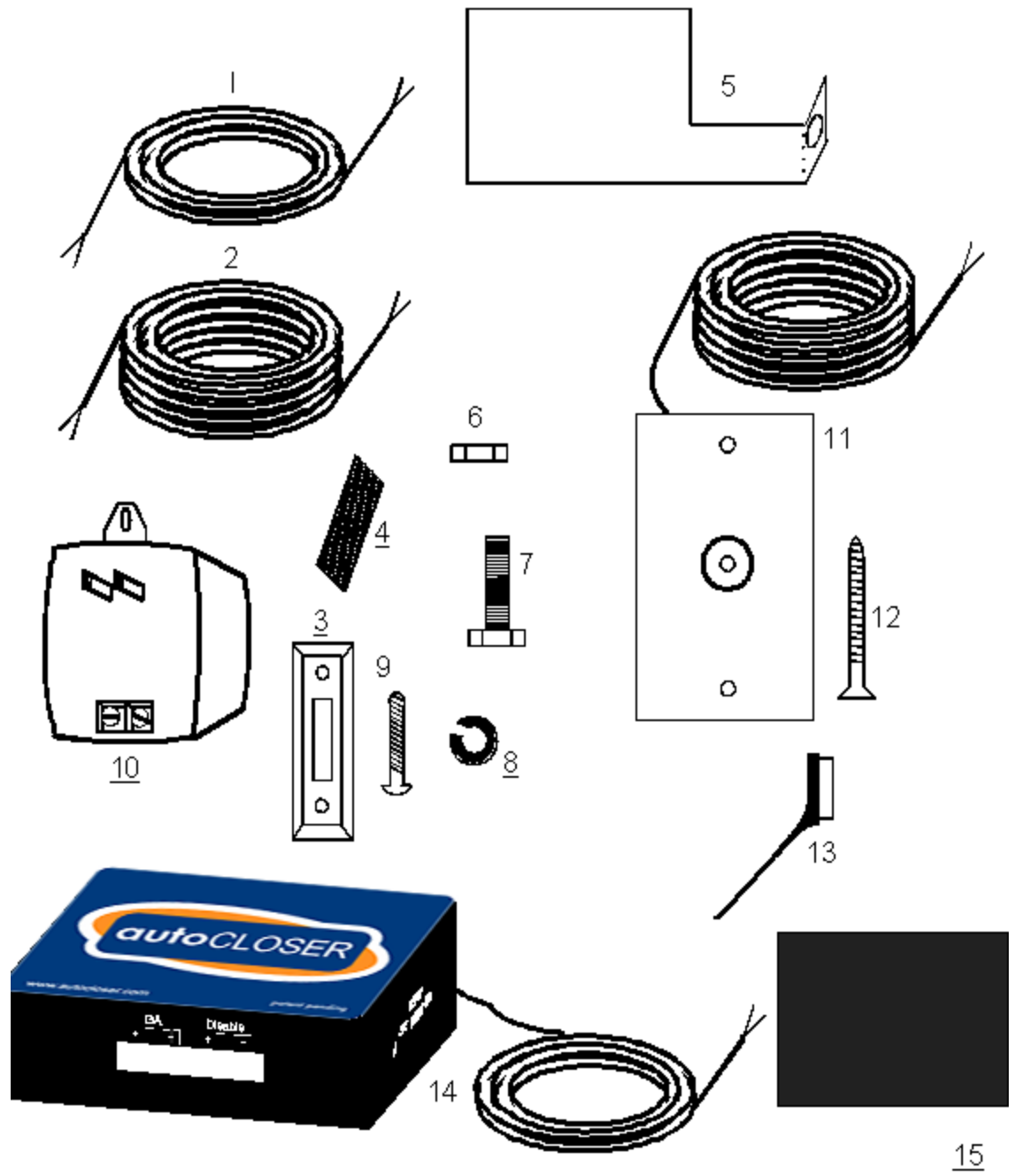

**PARTS IDENTIFICATION**

# INSTALLATION OF Autocloser HARDWARE

**!!!WARNING!!!**

**To reduce the risk of severe injury or death:**  
Read all instructions before installing.

## 1. Install reflector assembly.

**1a.** OPEN YOUR GARAGE DOOR AND UNPLUG THE GARAGE DOOR OPENER BEFORE BEGINNING THIS STEP !!! Bolt the reflector assembly, Item (5), to the garage door opener J brace (**Fig. 1-1**).

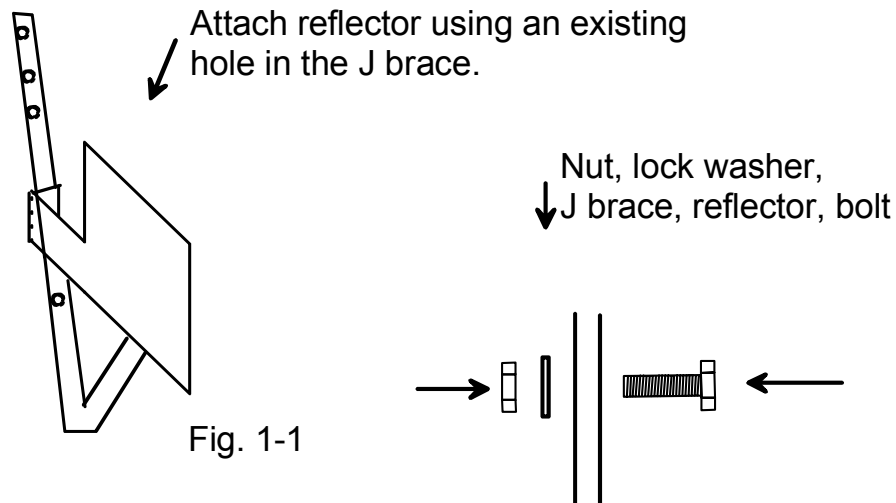

*TIP: In steps 3 and 4, the Autocloser control unit will be installed under the garage door opener power head assembly. The infrared sensor will be lined up with the reflector (**Fig. 1-2**) Install the reflector low enough on the J brace so that the infrared sensor on the Autocloser can be lined up with the reflector.*

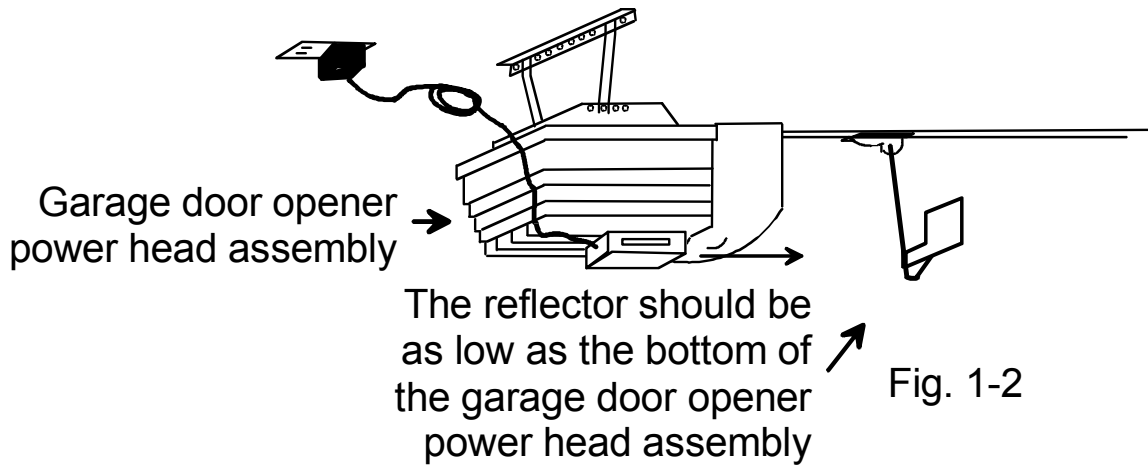

**1b. Attach reflective conspicuity tape to reflector plate.** Peel off adhesive backing from the conspicuity tape and affix to side of reflector plate facing the Autocloser unit. Tape should be aligned to cover most of the rectangular portion of reflector plate (**Fig. 1-3**).

NOTE: Conspicuity tape is a special form of reflective tape which will improve the reflective characteristics of the plate. The application of this tape will simplify the installation and enhance the performance of the unit.

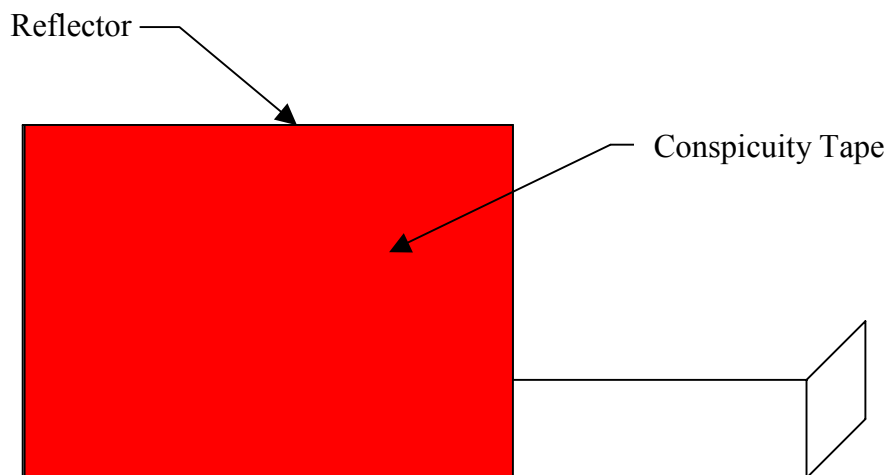

Fig. 1-3

2. **Connect power to the Autocloser.** The Autocloser uses a 110 Volt AC / DC power adapter. Attach each power wire to one of the screw terminals on the power adapter (**Fig. 2-1**). Either wire may be attached to either terminal.



Fig. 2-1

Unscrew the center screw on the plate of the household receptacle that you will be using to power the Autocloser. With the plate held in position, plug the Autocloser power adapter into the receptacle. Use the receptacle plate screw to screw down the adapter tab (**Fig. 2-2**).

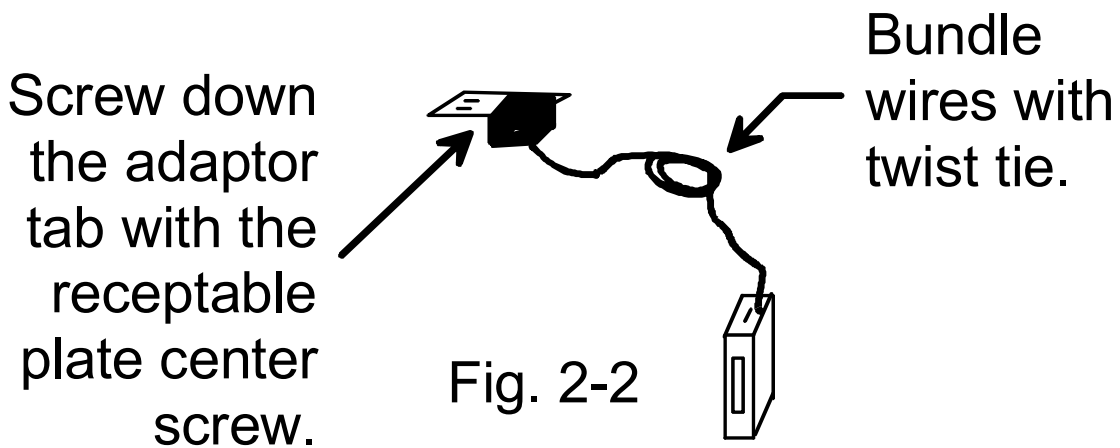

Fig. 2-2

**!!!WARNING!!!**

**THE POWER ADAPTER MUST BE SCREWED DOWN TO PREVENT THE ADAPTER FROM BEING ACCIDENTALLY UNPLUGGED. THIS ADAPTER IS HEAVY AND CAN CAUSE BODILY INJURY IF IT HITS SOMEONE!!!** Bundle excess wire in a roll and apply a twist tie, to prevent it from hanging down and becoming an obstruction.

3. **Determine the Autocloser mounting location.** The Autocloser uses an infrared emitter/detector to determine the position of the garage door. Note the position (**Fig. 3-1**) of the infrared sensors. To ensure correct operation, the Autocloser unit must be no more than 36 inches from the reflector plate when the door is fully open.

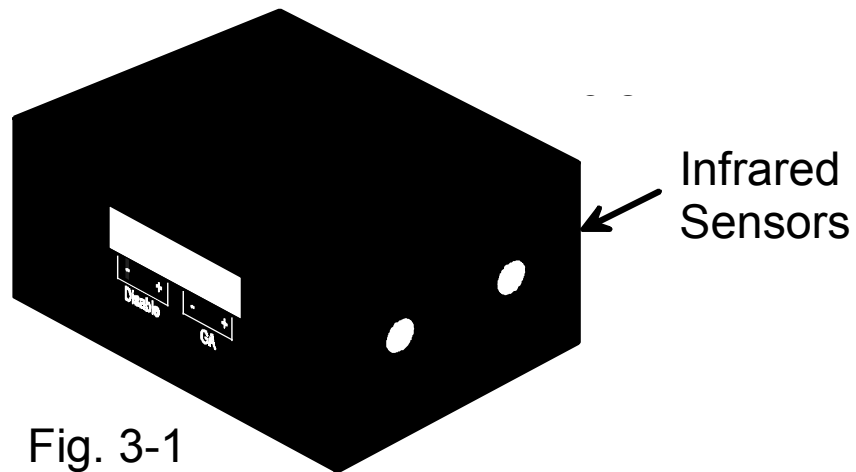
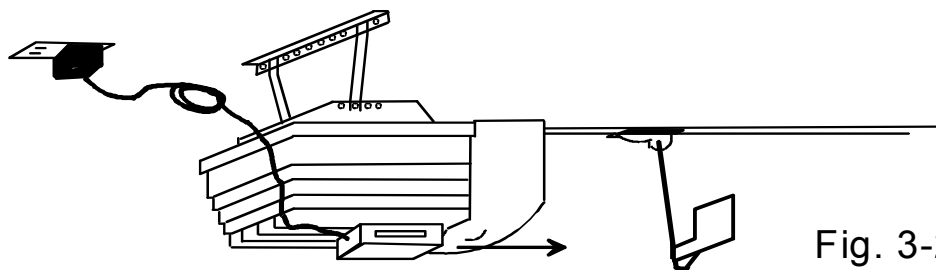

Fig. 3-1

The Autocloser must be mounted in a position with the infrared sensors aimed straight toward the reflector (**Fig. 3-2**). In order to accomplish this on all of the different shaped garage door openers available, the Autocloser box will always be mounted to the power head assembly.

*TIP: The Autocloser will need to be mounted at least 2 inches left or right of the center of the garage door opener to facilitate lining up the box and reflector.*



Position the Autocloser on the garage door opener motor housing with the label side down.

The infrared sensor should be in line with the reflector.

Switch the Autocloser to setup mode using the ON/OFF/SETUP switch on the back of the Autocloser unit (**Fig. 3-3**).

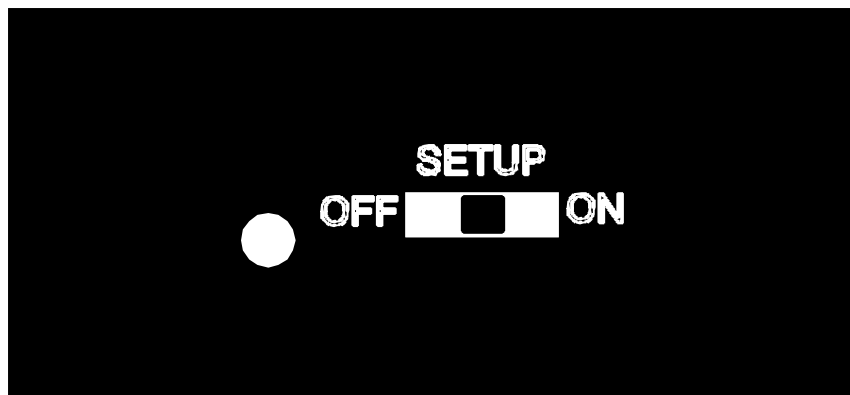

**Fig. 3-3**

Determine your mounting location by holding the Autocloser unit against the garage door opener power head assembly with the infrared sensor facing the reflector. While the Autocloser is in setup mode, it will emit a continuous audible alarm when the infrared sensor is within range and lined up with the reflector. Adjust the unit until it emits the continuous audible alarm. Mark the position of the unit by outlining it with a pencil (Fig. 3-4).

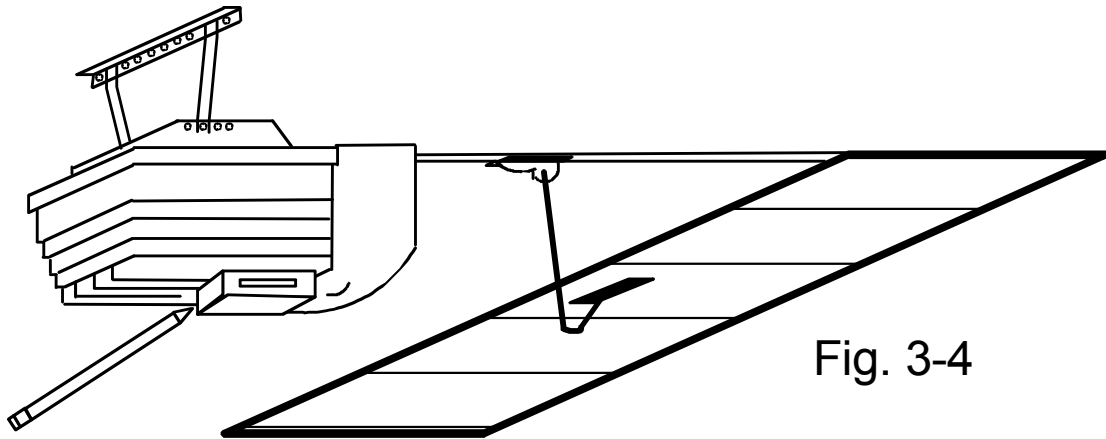

Fig. 3-4

**4. Apply Velcro<sup>®</sup> to the Autocloser unit and the garage door opener power head assembly (Fig. 4-1).** *TIP: Apply two parallel strips at the front and back of the outline and the unit.* The industrial strength, temperature resistant adhesive on the Velcro<sup>®</sup> strap is pressure activated. Use your finger to apply pressure and remove air bubbles. The adhesive is 80% cured in 1 hour and 100% cured in 24 hours. The Autocloser unit can be mounted before the adhesive is cured, but care should be exercised not to apply any pressure on the unit that will disturb the adhesive. Attach the Autocloser to the Velcro<sup>®</sup> strapping on the garage door opener. As in step 3, verify that the reflector and system are aligned.

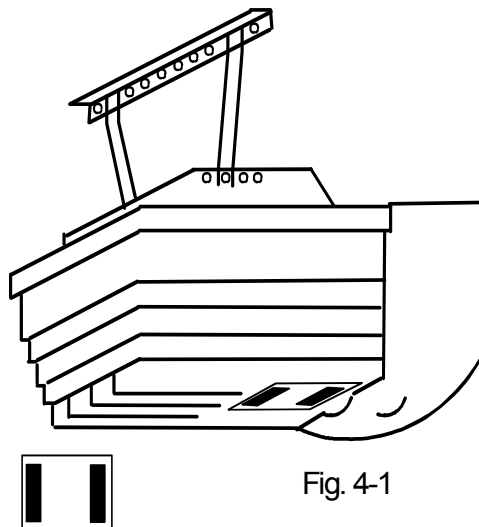
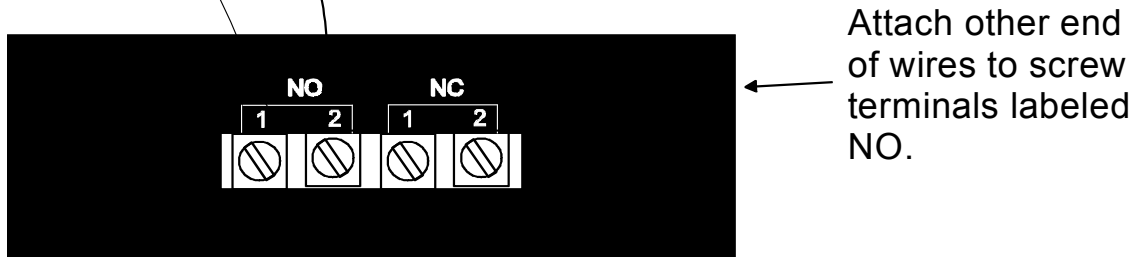
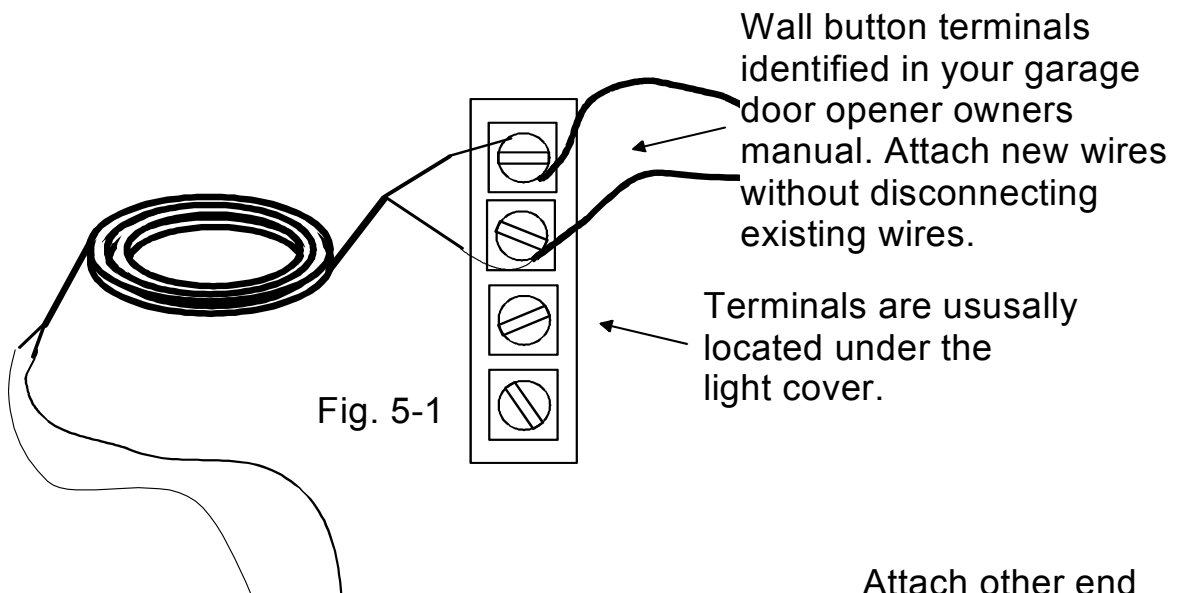

Fig. 4-1

5. **Wire the Autocloser to the garage door opener.** Read your garage door opener manual to determine where the wall button terminals are located on the power head. Strip the wires on one end of Item (1). Attach one of the wires of Item (1) to each of the screw terminals taking care not to disconnect the wall button wires already attached to the terminals. **(Fig. 5-1)** Approximate the length of the wire needed to connect to the Autocloser unit. Add a little extra length to this approximation and cut the wire. Strip the wires on this end of Item (1) and attach one of the wires to each of the screw terminals labeled 'NO' on the Autocloser unit **(Fig. 5-2)**.

**NOTE:** Read carefully and then remove the brightly colored warning label on the side of the Autocloser unit. The 'NO' terminals are under the warning label.



- Wire the disable button to the Autocloser.** Locate the disable button next to the garage door opener wall button. Attach one end of each wire, Item (2) to the disable button terminals, Item (3). Attach the disable button to the wall using the provided screws. Run the wire from the disable button to the Autocloser unit, attaching the wire to the wall and ceiling using insulated staples (not included) (**Fig. 6-1**).

*TIP: Route the wires through the notch in the disable button case so that it will fit snugly against the wall.*

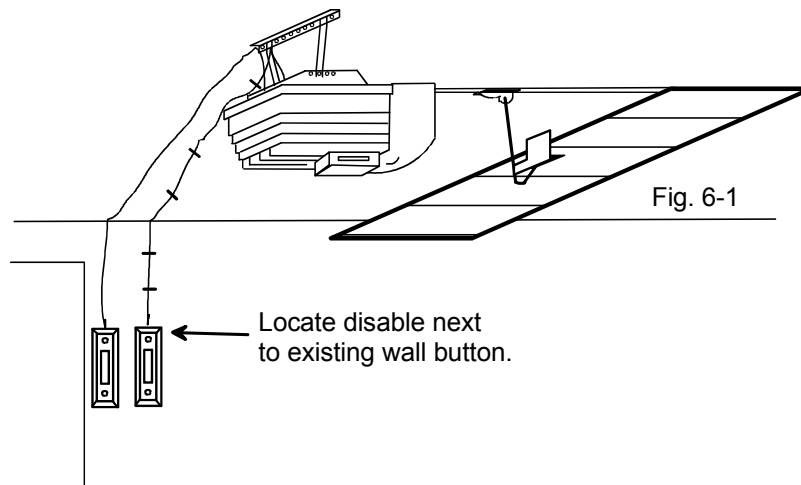

Approximate the length of the wire needed to connect to the Autocloser unit. Add one foot to this approximation and cut the wire. Strip the wires on this end of Item (2) and attach one of the wires to each of the screw terminals labeled 'Disable +/-' on the Autocloser unit. (Either wire can be connected to either terminal) (**Fig. 6-2**).

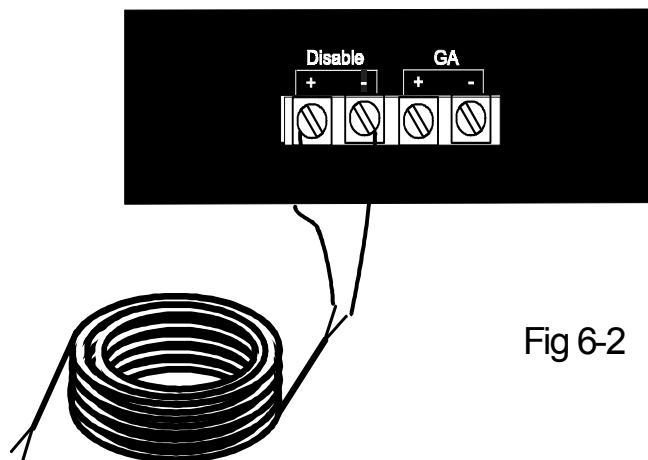

7. **Test the Autocloser system.** Plug in the garage door opener.
  - A. Switch the system to on. Close then reopen the garage door. As soon as the door is open, the system will start a software timer. The default door closer delay time is 5 minutes. When the timer completes this five-minute count, the system will begin to emit an audible beep. Thirty seconds after the beeping begins, the door will partially close, then reopen. After a brief period of time, the door will close.
  - B. Reopen the door. Press the disable button and then release. The Autocloser will beep twice to indicate that the unit has been placed into 'temporary disable'. The red disable LED will begin to blink. The door will not automatically close until the system is taken out of disable mode by closing the door.

**!!!WARNING!!!**

**The disable button is not a safety feature. The disable button will not reverse a door that is moving. If the door is closing and needs to be stopped, the garage door opener button should be pushed! The disable button is intended to temporarily disable the system so that the garage door can be left open. If the power goes out while the unit is in disable mode, the unit will restart in disable mode once the power is restored. To permanently disable the system, turn off the Autocloser using the on/off switch.**

*TIP- The disable button can be pressed during the audible alarm to reset the timer in order to give additional time before the unit auto closes the garage door. To put the unit in disable mode, press the disable button again.*

- C. Press the disable button again. The Autocloser will beep twice while the button is in and six times when it is released in order to indicate that the unit has already been placed in temporary disable. The unit can only be re-enabled by closing the garage door. Press the garage door opener wall button. The Autocloser will beep twice once the door begins to close and the disable light will stop blinking. This indicates that the Autocloser is no longer in 'temporary disable'. Once the door is closed, press the disable button again. The unit will beep twice while the button is in and six times when it is released to indicate that the door is closed and cannot be placed in 'temporary disable' mode.
- D. Open the door. Simulate an obstruction in the doorway by placing a 2X4 across the middle of the door threshold.

**!!!WARNING!!!**

**STAY AWAY FROM THE DOOR WHILE IT IS CLOSING - THE GARAGE DOOR CAN CAUSE SEVERE INJURY!!!**

When the timer finishes its count, the system will perform the door closing procedure. When the door hits the obstruction, it should return to the open position. The Autocloser will attempt to close the door twice. When the Autocloser has finished its closing cycle, it will sense that the door has not closed and transition to 'malfunction disable' mode. Note: the red disable LED will begin to blink and the unit will beep once every 20 seconds. Press the disable button to exit malfunction disable. The Autocloser will beep three times to indicate that it is leaving the malfunction disable mode and returning to normal operational mode.

*TIP: To minimize the time required to test, set the Autocloser delay time to two minutes. (see Operation and Programming Item (4).)*

- E. Open the door. Simulate an obstruction in the doorway by placing a piece of masking tape (non-clear) over one of the photo eye lenses.

**STAY AWAY FROM THE DOOR WHILE IT IS CLOSING - THE GARAGE DOOR CAN CAUSE SEVERE INJURY!!!**

When the timer finishes its count, the system will perform the door closing procedure. The photo eye system should allow the door to move only slightly. When the Autocloser has finished its closing cycle, it will sense that the door has not closed and transition to malfunction disable mode. Note: the red disable LED will begin to blink and the unit will beep once every 20 seconds. Remove the tape from the photo eye. Press the disable button to exit malfunction disable mode. The Autocloser will beep three times to indicate that it is leaving the malfunction disable mode and returning to normal operational mode

- F. Test for false reflections. Shut the garage door and switch the unit to 'Set Up' mode. Verify that the beeper does not make any noise. If the beeper is sounding, make sure there is nothing in front of the Autocloser unit causing false reflections.
- G. Installation of your Autocloser unit is complete. If you purchased an optional I-Opener, proceed to the I-Opener installation instructions. If you did not purchase an I-Opener, proceed to the Operation and Programming instructions. If you did not purchase an I-Opener, one can be purchased and added at any time by visiting our website: [www.autocloser.com](http://www.autocloser.com), or by calling 1-877-SHUT DOOR (1-877-748-8366) or 972-690-5255.

## ***INSTALLATION OF OPTIONAL I-Opener subsystem HARDWARE***

The I-Opener subsystem can be installed anytime after the Autocloser has been installed.

**!!!WARNING!!!**

**OPEN YOUR GARAGE DOOR AND UNPLUG THE GARAGE DOOR OPENER BEFORE BEGINNING THIS INSTALLATION !!!**

- 8. Determine I-Opener terminal mounting location.** The weather resistant I-Opener terminal, Item (11), can be mounted anywhere on the outside of your garage where a drill hole can be made. The system cannot be installed on the garage door itself. We suggest using the garage doorframe. This location will provide limited shelter and the typical wooden frame will be easy to drill. Using the I-Opener terminal plate as a template, sketch the approximate position of the terminal (**Fig. 8**).

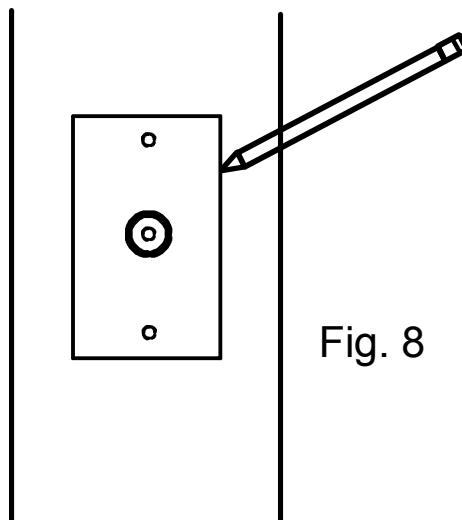

- 9. Drill holes for the I-Opener wire harness.** Visually inspect the opposite side of the doorframe for wires and other objects that may be damaged by the drill. Estimate the center of the sketch. Using a 7/16-inch drill, make a 7/16-inch hole through the center of the sketch. Feed all of the I-Opener terminal wire through the hole (**Fig. 9**).

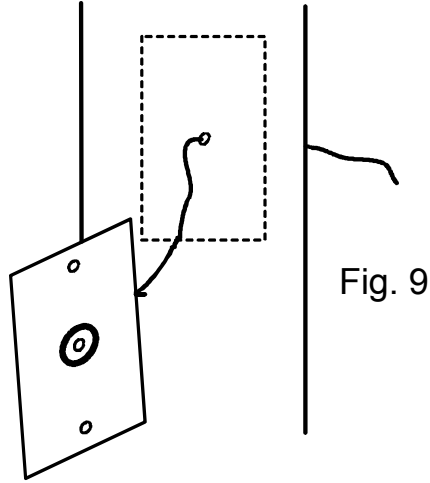

10. **Drill holes for the I-Opener terminal plate.** Position the back of the terminal in the hole. Mark the terminal plate holes with a pencil. Remove the terminal plate and drill the plate holes with a 1/8-inch drill.
11. **Fasten the terminal plate to the doorframe.** Reposition the terminal plate with terminal in the hole. Use 1 inch #8 wood screws, Item (12), to fasten the plate to the doorframe (**Fig. 11**).

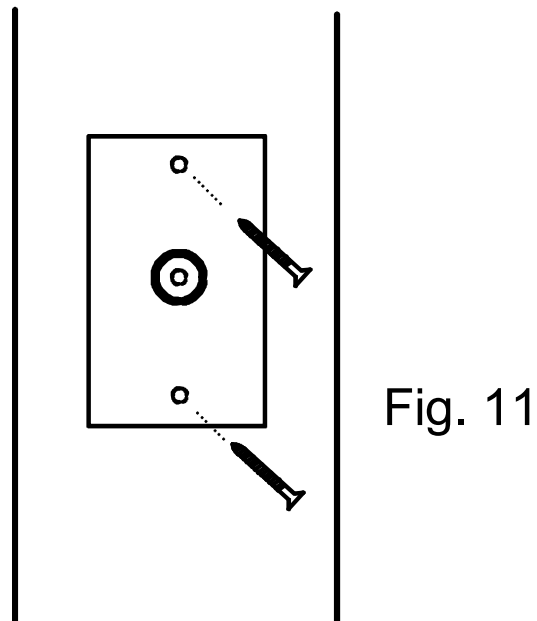

**12. Wire the I-Opener terminal to the Autocloser.** Run the wire from the I-Opener terminal to the Autocloser unit attaching the wire to the wall and ceiling using insulated staples (not included) (**Fig. 12-1**).

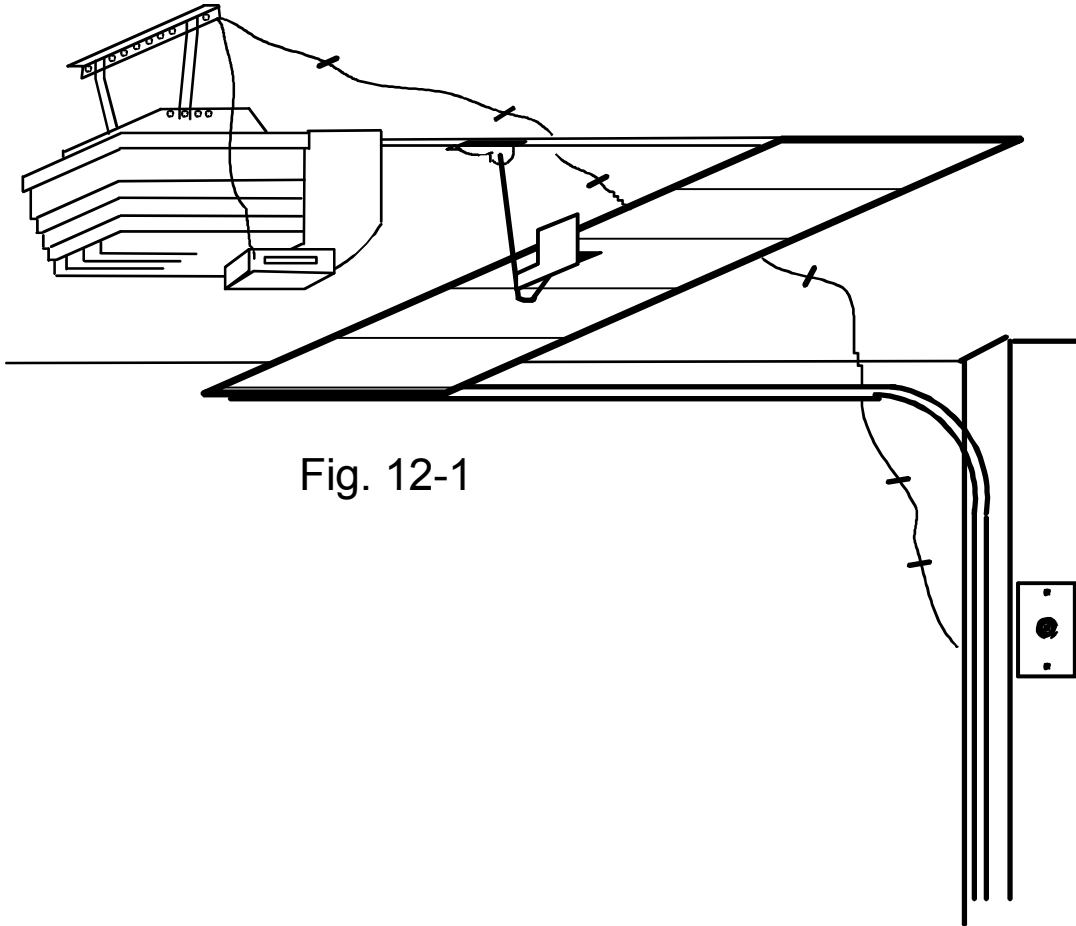

Approximate the length of the wire needed to connect to the Autocloser. Add one foot to this approximation and cut the wire. Strip the wires on this end of Item (11). Attach the colored or striped wire to the screw terminal labeled GA + on the Autocloser box. Attach the white wire to the screw terminal labeled GA - on the Autocloser unit. (**Fig. 12-2**).

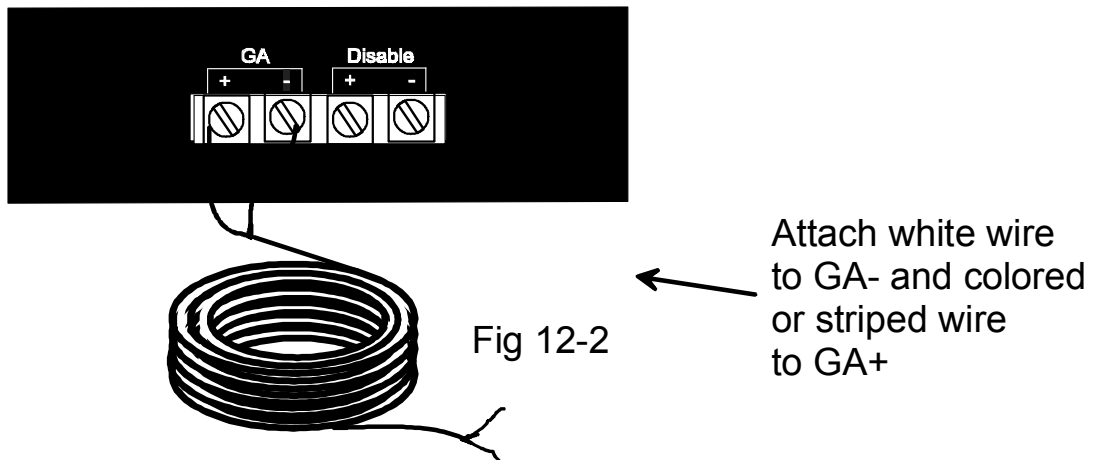

13. **Insure that nobody is standing under the garage door.** Plug the garage door opener back into its 110 Volt household receptacle.
14. **Program your I-Opener electronic key.** Your I-Opener system will remember up to nine electronic key codes at a given time. Have all of the keys present when programming the system. Switch the Autocloser to setup mode. Press each key into the I-Opener terminal for 2 seconds. The Autocloser will beep 3 times after each key is read. When all of the keys have been read, switch the Autocloser to on mode. Test each key by pressing it into the I-Opener terminal. (Remember: Whenever one key is programmed, all keys must be reprogrammed.) To erase all key codes from the Autocloser, press the disable button while the unit is in setup mode.

## OPERATION AND PROGRAMMING

The Autocloser system is ready to operate straight out of the box. Once installed, the unit will automatically close your garage door after the preset software timer has finished its count. The system features are enumerated below.

- 1) Temporary Disable - This disable is intended to temporarily disable the system so that the garage door will not automatically close. This feature can only be utilized when the garage door is fully open. To activate 'temporary disable', press the disable button when the garage door is open—NOTE: The door must be completely open in order for the disable button to be recognized. The Autocloser will beep twice indicating that the unit is in 'temporary disable'. The red disable light will begin to blink. To deactivate 'temporary disable', close the garage door. Pressing the disable button a second time while the garage door is open will not deactivate 'temporary disable'. If the disable button is pressed while the unit is in 'temporary disable', the Autocloser will signal the error with two beeps while the button is depressed, followed by six beeps when the button is released. The Autocloser will remember that it is in this mode if the power is interrupted.

*TIP- If the garage door is partially closed, the Autocloser will think the door is fully closed and will never perform the auto closing function. Because the unit thinks the door is closed, it cannot be put into 'temporary disable'.*

- 2) Malfunction Disable - This disable occurs automatically when the garage door fails to close after two Autocloser attempts. When the unit is in 'malfunction disable' mode, the red disable light will blink and the unit will beep once every 20 seconds. Determine if something is blocking your garage door then re-enable the unit by pressing the disable button. The unit will beep 3 times.
- 3) Auto close Cancel - To cancel the current auto closing operation when the unit is sounding the audible closing alarm (auto close state), the operation can be cancelled by pressing the disable button. This will reset the software timer. The unit will immediately begin counting.

**!!!WARNING!!!**

**The auto close cancel feature WILL NOT reverse a door that is already moving. This feature simply cancels further Autocloser operation. If the door is already closing and it needs to be stopped, the garage door opener button should be pushed!**

*TIP- The auto close cancel feature can be used whenever the Autocloser begins its continuous warning beeps.*

- 4) Set the auto close delay time - The delay time can be set to 2, 5, 10, 15 and 20 minutes. To set the delay time press and hold the disable button while the unit is in run mode. The unit will initially beep twice. The unit will sound a series of beeps every 5 seconds to signify the delay time that would be set if the disable button were released immediately.

1 beep => 2 minutes  
2 beeps=> 5 minutes  
3 beeps=> 10 minutes  
4 beeps=> 15 minutes  
5 beeps=> 20 minutes

After reaching 5 beeps, if you have missed the setting you desired, you may release the button and press it again to restart the sequence.

\*NOTE: It is recommended that you set your delay time for as short a delay as possible, to minimize the amount of time your garage is vulnerable to intruders.

- 5) Program I-buttons - Nine I-button key codes can be programmed into the system. All key codes must be programmed at the same time. To program the system, switch the unit to setup mode. Press each I-button into the I-Opener terminal for 2 seconds. (When the first I-button is pressed into the terminal, the system erases all previous I-button key codes.) The unit will beep 3 times after each I-button key code is recorded. When finished programming the I-buttons, switch the unit to on mode. Press each I-button into the terminal. The door should move when each I-button is tested.
- 6) Erase all I-buttons - If you lose one or more of your I-buttons, you should erase the key codes while waiting for replacements. Switch the unit to setup mode. Press the disable button. The system will beep 3 times to indicate that the I-button key codes have been erased. Switch the unit to 'ON' mode.
- 7) Autocloser/reflector alignment - To align the unit and reflector, switch the unit to setup mode and open the garage door. The system will beep continuously when the reflector is within three feet of, and aligned with, the Autocloser unit. Switch the unit to on mode.

## TROUBLE SHOOTING GUIDE

Please read this section carefully if your Autocloser does not function correctly.

<p>The unit does not beep or beeps intermittently when aligning the reflector while in setup mode</p>	<p><b>STEP 1</b></p> <ol style="list-style-type: none"><li>1) Make sure the switch is in the center position (setup mode).</li><li>2) Place hand about 6 inches in front of the infrared sensors. Does the Autocloser beep?<ul style="list-style-type: none"><li>• <b>Yes</b>- Re-align the reflector and make sure it is within three feet of the Autocloser when the garage door is open.</li><li>• <b>No</b>- Check the receptacle plug for power by plugging in another device into the outlet .Go to Step 2.</li></ul></li></ol> <p><b>STEP 2</b></p> <p>Does the electrical outlet work?</p> <ul style="list-style-type: none"><li>▪ <b>Yes</b>- Please contact Xceltronix, Inc. for possible warranty service.</li><li>▪ <b>No</b>- Fix Electrical outlet.</li></ul>
<p>After the door has been open for the set delay time, the unit does not beep.</p>	<p><b>STEP 3</b></p> <p>Is the garage door fully open?</p> <ul style="list-style-type: none"><li>▪ <b>No</b>- Open garage door and recheck.</li><li>▪ <b>Yes</b>- Go to Step 4.</li></ul>

#### STEP 4

Press and release the Disable button while the unit is on. Does the unit beep twice?

- **No**- Go to Step 1 and re-align the reflector.
- **Yes**- Go to Step 5

#### STEP 5

1) Are you sure you are waiting the full delay time?

- **No**- Press and hold the Disable button. The unit will beep twice initially, then after 5 seconds it will beep once. Release the disable button. This sets the delay time to 2 minutes.
- **Yes**- Go to Step 6

2) Retest Autocloser function and wait the full two minutes. Does the unit work?

- **No**- Go to Step 6
- **Yes**- Unit is working

#### STEP 6

- 1) Disconnect unit from the garage door opener.
- 2) Plug it in to any wall outlet.
- 3) Hold the unit about a foot away from the wall and switch it to 'setup'. It should continually beep.
- 4) Switch it to 'on'.
- 5) Hold the unit about a foot away from the wall.
- 6) Wait for the delay timer to complete it's count (Remember to keep holding the unit facing the wall. If the unit doesn't think the reflector is in the open position, it will not go into closer mode.) The unit should begin beeping after the delay timer finishes it's count.

	<p>7) Unit begins to beep?</p> <ul style="list-style-type: none"> <li>▪ <b>Yes</b>- Unit is working. Follow all installation steps.</li> <li>▪ <b>No</b>- please contact Xceltronix, Inc. for possible warranty service.</li> </ul>
<p>The I-Opener system doesn't work</p>	<p><b>STEP 7</b></p> <ol style="list-style-type: none"> <li>1) Switch unit into setup mode.</li> <li>2) Press the disable button. Unit should beep three times.</li> <li>3) Unit beeps three times? <ul style="list-style-type: none"> <li>▪ <b>Yes</b>- I-button key codes have now been erased. Go to Step 8</li> <li>▪ <b>No</b>- Make sure the switch is in the center position (setup mode).</li> </ul> </li> </ol> <p><b>STEP 8</b></p> <ol style="list-style-type: none"> <li>1) While in setup mode. Press an I-Opener I-button into the I-Opener terminal. Unit should beep three times.</li> </ol>

- 2) Unit beeps three times?
- **Yes**- Unit has been programmed with this I-button key code. Go to Step 9
  - **No**- Go to Step 10

**STEP 9**

- 1) Switch unit into on mode.
- 2) Press an I-Opener I-button into the I-Opener terminal. Unit should operate garage door.
- 3) Unit operates door?
  - **Yes**- Unit is working
  - **No**- Please contact Xceltronix, Inc. for possible warranty service.

**STEP 10**

- 1) Check I-Opener terminal connection at the Autocloser. The colored or striped wire should be connected to the GA+ and the white wire should be connected to the GA-
- 2) Is this the first time you have gone through these tests?
  - **Yes**- Go to Step 7
  - **No**- Please contact Xceltronix, Inc. for possible warranty service.

## **LIMITED LIFETIME WARRANTY**

**What does the warranty cover?** Any defect in parts and product workmanship that arises from normal household use in accordance with the Installation Manual and User's Guide.

**How long does the warranty last?** Parts are warranted for life\* and labor is warranted for 90 days from the date of purchase.

\*Lifetime warranty only applies to the original owner. The product must be registered using the form at the end of this manual or the original proof of purchase must be shown to receive warranty service.

**Who gets the warranty?** This warranty is limited to the consumer who originally purchased the product.

**How does the warranty service work?** If the Autocloser is defective, we will repair or, at our option, replace it. If we repair your product, we may use new or reconditioned replacement parts. If we choose to replace your Autocloser, we may replace it with a new or reconditioned unit of the same or similar design. During the first 90 days from the date of purchase, all parts and labor are free of charge. After the first 90 days from the date of purchase, all parts are free and a nominal diagnosis charge will be collected for labor.

**How is warranty service obtained?** We suggest that you retain your original packing materials in the event you need to ship your Autocloser. Ship the unit to:

**Xceltronix, Inc.  
Attn: Warranty Service Dept.  
661 N. Plano Rd. Suite 315  
Richardson, TX 75081**

Include your name, address, telephone number, proof of date and place of purchase, and a description of the problem. If you contact Xceltronix, Inc. or mail the unit after the first 90 days from the date of purchase, you will be charged a bench fee of \$25.00 to repair or, at our option, replace the unit.

**What does the warranty not cover?** This warranty does not cover installation, defects resulting from accidents, misuse or abuse, unauthorized repair or modification, fire, flood, other natural disasters or acts of war.

## FAQ

1. Can I have my unit professionally installed? Xceltronix, Inc. is partnering with local professional garage door installers to provide set pricing on professional inspection and installation. Please go to <http://www.autocloser.com/> for a list of approved installers.
2. Why does my garage door opener need to be fully consumer product safety commission compliant in order to be used with the Autocloser? The Autocloser relies on safety features mandated by congress, and detailed by the consumer products safety commission, in order to protect your home and family from accidents related to garage doors.
3. When adjusting the reflector, should the unit beep continuously when the door reflector is aligned? Yes, the unit will continually beep if the door is fully open, the reflector is aligned and the unit is in setup mode.
4. What happens if I push the garage door opener wall button while the door is closing? The Autocloser will attempt to close your garage door two times. If you push the wall button while the door is closing the first time, the door will either stop closing or reverse and re-open. The Autocloser will then check to see if the door closed. If the door stops and is far enough away from the door detector, the Autocloser will think the door is shut and transition to monitor mode. If the door re-opens, the Autocloser will detect the open door and attempt to close it one more time. If you push the wall button while the door is closing the second time, the door will either stop closing or reverse and re-open. The Autocloser will then check to see if the door closed. If the door stops and is far enough away from the door detector, the Autocloser will think the door is shut and transition to monitor mode. If the door re-opens, the Autocloser will detect the open door and transition to malfunction disable mode due to the door failure. The disable button must then be pushed in order to put the Autocloser back into monitor mode.
5. Will pressing the disable button stop a garage door that is already moving? The disable button WILL NOT stop a moving garage door. Press the garage door opener wall control button to reverse a moving garage door. The disable button only affects the Autocloser, not the garage door opener.

6. Do I have to install the disable button? Yes, while the unit will work without the disable button installed, it is needed to re-enable the system after a malfunction. The disable is also a convenient way to temporarily disable the unit without turning it off.
7. I returned home to find my garage door open. Why did my Autocloser fail to close my garage door? If you hear a beep once every 20 seconds and find the disable LED blinking, the unit did attempt to close the door. The Autocloser will attempt to close your garage door 2 times. Reasons why the door might re-open include binding door wheels or an obstruction in the path of the door. The Autocloser may have attempted to close the door but failed due to the previous reasons. The Autocloser does not interfere with the mandatory safety features included on modern garage door openers. Re-enable the Autocloser by pressing the disable button.
8. I lost one of my I-Opener electronic keys. How do I erase the lost key's serial number? Switch the Autocloser to setup mode and press the disable button. All key codes are now erased. Reprogram your remaining keys by following step 5 in the Operation and Programming section of this manual.
9. Can a burglar open my garage by shorting out the I-Opener terminal? No, the Autocloser reads the unique electronic key code and compares it to the pre-programmed key codes before it opens the door. It would be virtually impossible to simulate the electronic key's code.
10. Can I order additional keys? Yes, please log on to <http://www.autocloser.com/> for ordering information.
11. Does my unit come with a warranty? Yes, we are pleased to offer you a limited lifetime warranty. Read the warranty section of this manual for full details. In order to obtain warranty service you must provide proof of the date and place of purchase of the product. To insure this, fill in the enclosed warranty card and mail to: Xceltronix, Inc., 661 N. Plano Rd., Suite 315, Richardson, TX 75081 Include a copy of your sales receipt with the date of purchase.

## **REPLACEMENT PARTS**

To order replacement parts visit our website at:

[www.autocloser.com](http://www.autocloser.com)

Or contact us:



Xceltronix, Inc.  
661 N. Plano Rd.  
Suite 315  
Richardson, TX 75081  
1-877-748-8366 (1-877-SHUT DOOR)  
or 972-690-5255



# Autocloser Warranty

First Name

Last Name

---

Address

---

City

State

Zip Code

---

Phone #

---

Email Address

Date of Purchase

---

Limited Lifetime Warranty: read the warranty section  
in the Installation Manual and User's Guide for details.

Please mail to: Xceltronix, Inc.  
661 N. Plano Rd.  
Suite 315  
Richardson, TX 75081